



**STRONG PARTNERS.  
TOUGH TRUCKS.™**



# **PC1.5 SERIES TECHNICAL GUIDE**



**[WWW.HYSTER.COM](http://WWW.HYSTER.COM)**

# > PC1.5 SPECIFICATIONS

GENERAL	1-1	Manufacturer	HYSTER		
	1-2	Model designation	PC1.5		
	1-3	Drive	Electric (battery)		
	1-4	Operator type	Pedestrian		
	1-5	Rated capacity / rated load	Q <sub>1</sub>	t	1.5
	1-6	Load centre distance	c	mm	600
	1-8	Load distance, centre of drive axle to fork	x	mm	952   1022
	1-9	Wheelbase	y	mm	1197   1267
	WEIGHT	2-1	Service weight		kg
2-2		Axle loading with load, front / rear		kg	1134   486
2-3		Axle loading without load, front / rear		kg	88   32
WHEELS	3-1	Tyre type	polyurethane / polyurethane		
	3-2	Tyre size, front		mm	140 x 55
	3-3	Tyre size, front		mm	80 x 93 (single wheel) / 80 x 70 (dual tandem wheel)
	3-5	Wheels, number front / rear (x = driven wheels)			1x / 2 (single wheel) / 1x / 4 (dual tandem wheel)
	3-7	Tread, rear	b <sub>11</sub>	mm	385   520
DIMENSIONS	4-4	Lift	h <sub>3</sub>	mm	115
	4-9	Height drawbar in driving position min./max.	h <sub>14</sub>	mm	1552   1622
	4-15	Height, lowered	h <sub>13</sub>	mm	82 ± 2
	4-19	Overall length (pedestrian)	l <sub>1</sub>	mm	1552 / 1622
	4-20	Length to face of forks (pedestrian)	l <sub>2</sub>	mm	1150 / 1220
	4-21	Overall width	b <sub>1</sub> /b <sub>2</sub>	mm	550   685
	4-22	Fork dimensions DIN ISO 2331	s/e/l	mm	58 x 160 x 1150 (1220)
	4-25	Distance between fork-arms	b <sub>5</sub>	mm	550   685
	4-32	Ground clearance, centre of wheelbase	m <sub>2</sub>	mm	22
	4-34-1	Aisle width for pallets 1000 × 1200 crossways	A <sub>st</sub>	mm	1718
	4-34-4	Aisle width for pallets 800 × 1200 lengthways	A <sub>st</sub>	mm	1687
	4-35	Turning radius	W <sub>a</sub>	mm	1353   1426
	PERFORMANCE	5-1	Travel speed with / without load		km/h
5-1-1		Travel speed with / without load, backwards (pedestrian)		km/h	4.0   5.0
5-2		Lifting speed with / without load		m/s	0.018   0.023
5-3		Lowering speed with / without load		m/s	0.056   0.046
5-7		Gradeability - 1.6 km/h, with / without load		%	6%   20%
5-8		Max. gradeability - 1.6 km/h, with / without load		%	6%   20%
5-10		Service brake			Electric
ELECTRIC MOTOR	6-1	Drive motor, S2 60 min rating		kW	0.75KW
	6-2	Lift motor S3 15% rating		kW	0.5KW
	6-3	Battery according to DIN 43531/35/36 A,B,C, no			no
	6-4	Battery voltage / nominal capacity K5		V/Ah	48V / 10Ah   48V / 15Ah
	6-5	Battery weight		kg	4.5   5.9
	6-6	Energy consumption acc. to VDI cycle		kWh/h	0.42 Kwh/h
	8-1	Type of drive unit			Electric
10-7	Average noise level at the operator's ear according to EN 12053		dB (A)	69	

## NOTICE:

Care must be exercised when handling elevated loads. Operators must be trained and must read, understand and follow the instructions contained in the Operating Manual.

All values are nominal values and they are subject to tolerances. For further information, please contact the manufacturer.

Hyster products are subject to change without notice. Lift trucks illustrated may feature optional equipment. Values may vary with alternative configurations.

**CE** Safety: This truck conforms to the current EU requirements.

Specification data is based on VDI 2198.



# TRUCK DIMENSIONS <

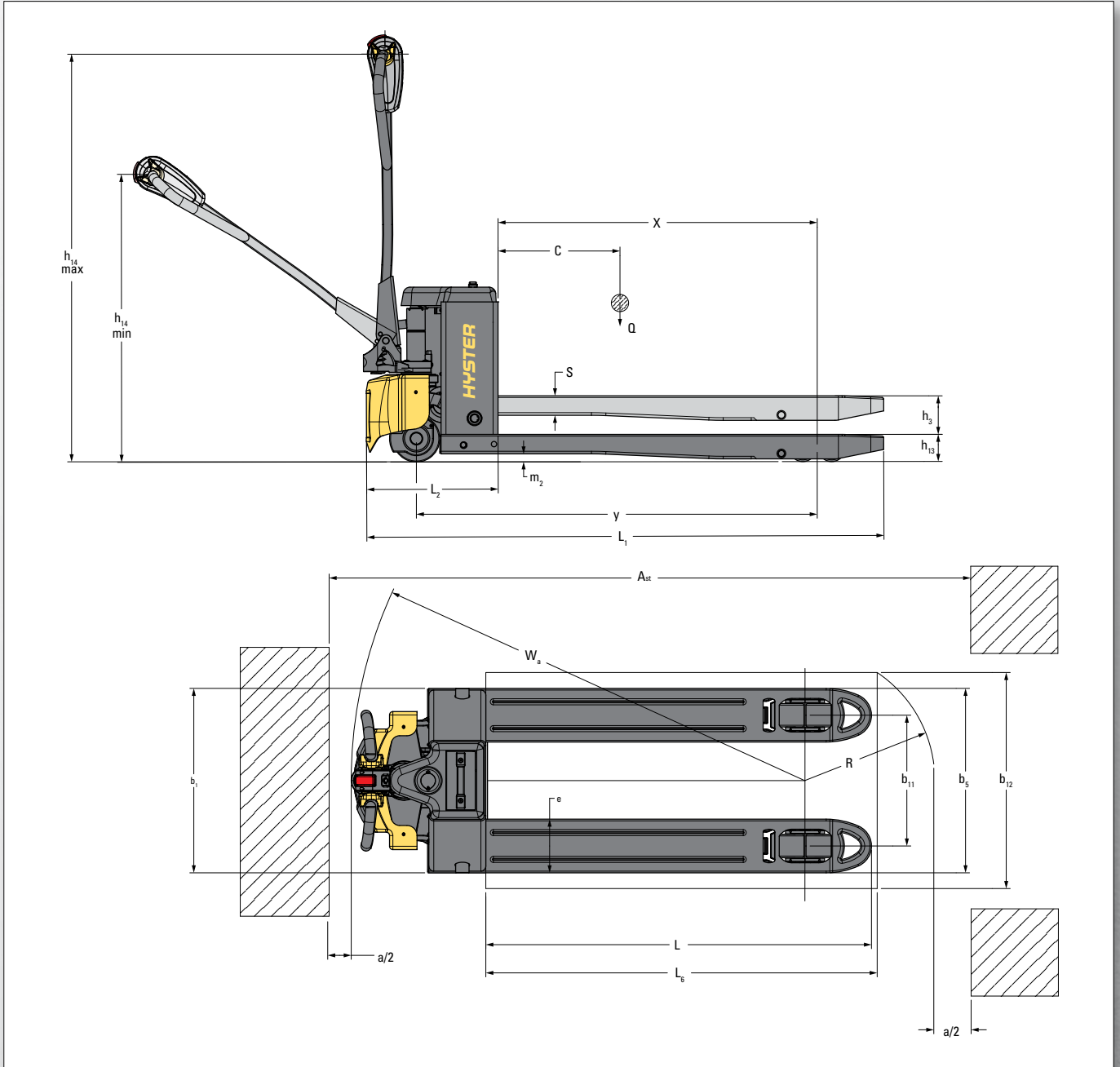

# POWERED PALLET TRUCK VS. HAND PALLET TRUCK <

**SERVICE WEIGHT**

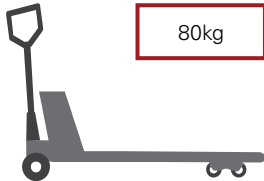
	120kg		80kg
1552mm		1510mm	

Compact and Lightweight



Single/Dual Tandem Load Wheels



Protective Cover

# STRONG PARTNERS. TOUGH TRUCKS.™

## FOR DEMANDING OPERATIONS, EVERYWHERE.

Hyster® supplies a complete range of warehouse equipment, IC and electric counterbalanced trucks, container handlers and reach stackers. Hyster® is committed to being much more than a lift truck supplier.

Our aim is to offer a complete partnership capable of responding to the full spectrum of material handling issues: whether you need professional consultancy on your fleet management, fully qualified service support, or reliable parts supply, you can depend on Hyster®.

Our network of highly trained dealers provides expert, responsive local support. They can offer cost-effective finance packages and introduce effectively managed maintenance programmes to ensure that you get the best possible value. Our business is dealing with your material handling needs so you can focus on the success of your business today and in the future.



### HYSTER EUROPE

Centennial House, Frimley Business Park, Frimley, Surrey, GU16 7SG, England.

Tel: +44 (0) 1276 538500



[www.hyster.eu](http://www.hyster.eu)



[infoeurope@hyster.com](mailto:infoeurope@hyster.com)



[/HysterEurope](https://www.facebook.com/HysterEurope)



[@HysterEurope](https://twitter.com/HysterEurope)



[/HysterEurope](https://www.youtube.com/HysterEurope)



HYSTER-YALE UK LIMITED trading as Hyster Europe. Registered Address: Centennial House, Building 4.5, Frimley Business Park, Frimley, Surrey GU16 7SG, United Kingdom. Registered in England and Wales. Company Registration Number: 02636775.

©2020 HYSTER-YALE UK LIMITED, all rights reserved. HYSTER, , and STRONG PARTNERS. TOUGH TRUCKS. are trademarks of HYSTER-YALE Group, Inc.

Hyster products are subject to change without notice. Forklift trucks illustrated may feature optional equipment.